

DESIGN FEATURES

- Built-in ISO 5211 Mounting Pad Easy Automation
- Fire Safe Design Approved
- Anti-static Devices for Ball-Stem-Body
- Blow-out Proof Stem
- Pressure Balance Hole in Ball Slot
- NACE standard MR0175 & MR0103 (Optional)
- Casting Approved by TÜV AD 2000-Merkblatt W0

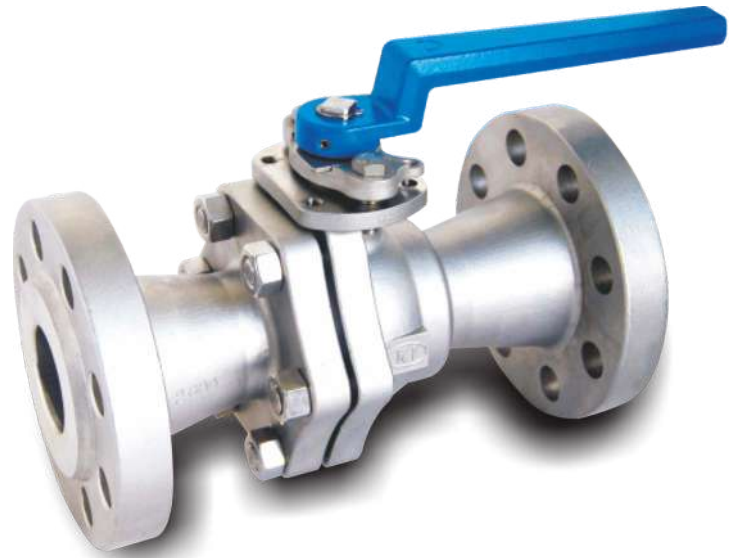

APPLICABLE STANDARDS

- Design Standard : ASME B16.34
- Frie Design : API 607 5th 2005, ISO10497
- Face To Face : ASME B16.10
- Flanged End : ASME B16.5 Class 600
- Inspection & Testing : API 598

TORQUE VALUES

Close to Open Torque at Various Differential Pressure (ΔP), Standard Seats (TFM4215)

Size\ ΔP	75psig		150psig		300psig		700psig		1000psig		1500psig	
	5bar		10bar		20bar		50bar		63bar		100bar	
NPS	N·m	In·lb	N·m	In·lb	N·m	In·lb	N·m	In·lb	N·m	In·lb	N·m	In·lb
1/2	7	62	7	62	7	62	7	62	7	62	7	62
3/4	8	71	8	71	8	71	8	71	8	71	8	71
1	13	115	13	115	15	133	15	133	15	133	15	133
1 1/4	17	150	17	150	20	177	22	195	25	221	26	230
1 1/2	25	221	25	221	29	257	31	274	34	301	37	328
2	33	292	33	292	42	372	46	407	49	434	55	487
2 1/2	52	460	59	522	64	566	70	620	77	681	85	752
3	85	752	94	832	105	929	117	1035	131	1159	146	1292
4	130	1150	143	1265	159	1407	176	1558	192	1699	211	1867

CV VALUES / WEIGHT

NPS	CV	KV	Weight (kg)	Weight (lb)
1/2	30	26	3.1	6.8
3/4	55	48	4.4	9.7
1	96	83	6.1	13.5
1 1/4	170	147	—	—
1 1/2	270	234	12.6	27.8
2	470	407	16.9	37.3
2 1/2	780	675	24.3	53.6
3	1150	995	34.5	76.1
4	2100	1817	68.6	151.3

Remark :

- 1.The torque figures at 5 bar pressure are maximum values to be tested after the valves are placed for 24 hours.
- 2.For actuator sizing, a safety factor of minimum 30% is recommended.
- 3.If the working temperature is larger than 180°C (356°F), additional safety factor of minimum 20% is recommended.

TECHNICAL INFORMATION



PRESSURE - TEMPERATURE DATA

The pressure-temperature data of ball valves is determined not only by valve shell materials but also by sealing materials used for ball seats, gland packings and flange gaskets.

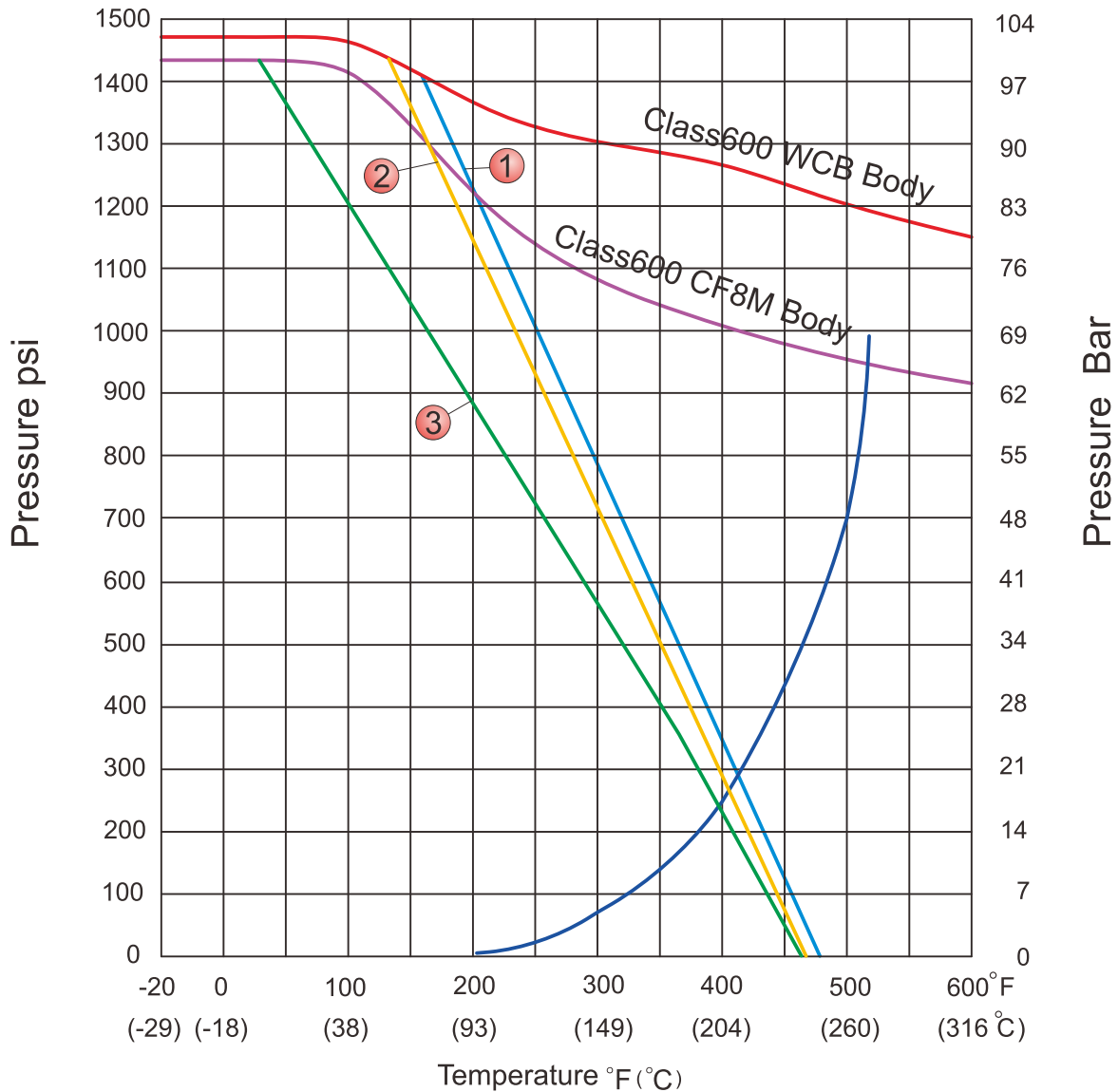

Seat Materials : TFM4215

① Full Bore : NPS ½ ~ NPS 1 ② Full Bore : NPS 1 ¼ ~ NPS 2 ½ ③ Full Bore : NPS 3 & NPS 4

Body Ratings: Shown above are for ASTM A351 Gr.CF8M and A216 Gr.WCB

For ratings of other valve shell materials, please refer to the last edition of ASME B16.34.

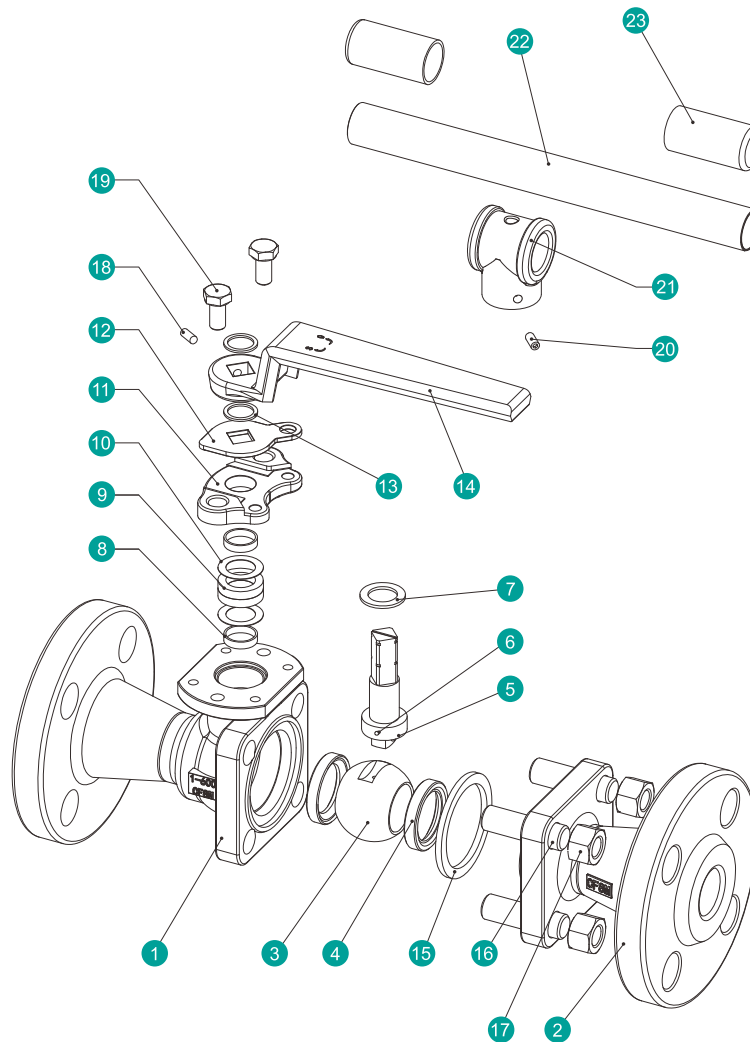
MATERIAL OF CONSTRUCTION

NO.	PART NAME	MATERIALS		
1	Body	A351-CF8M	A351-CF8	A216-WCB
2	Cap	A351-CF8M	A351-CF8	A216-WCB
3	Ball	316		304
4	Ball Seat		TFM4215	
5	Stem	316		304
6	Anti-Static	316		304
7	Thrust Washer	PTFE/TFM1600		
8	Stem Jacket	PTFE		
9	Packing	PTFE / GRAPHITE*		
10	Bushing	316		
11	Packing Gland	CF8		
12	Triangle Stopper	304		
13	Snap Ring	304		
14	Handle (NPS 1/2 ~ 2 1/2)	WCB		
15	Body Gasket	PTFE / 316 Spiral Wound+GRAPHITE*		
16	Bolting	A193-B8		A193-B7
17	Bolt Nut	A194-8		A194-2H
18	Set Screwed (NPS 1/2 ~ 2 1/2)	A2-70		
19	Bolting	A2-70		
20	Set Screwed (NPS3 & NPS4)	A2-70		
21	Handle Adapter (NPS3 & NPS4)	A351-CF8		
22	Handle (NPS3 & NPS4)	A53+ZnPlated		
23	Handle Sleeve (NPS3 & NPS4)	PVC		

*Materials for KV-063 Series (Fire Safe Models)

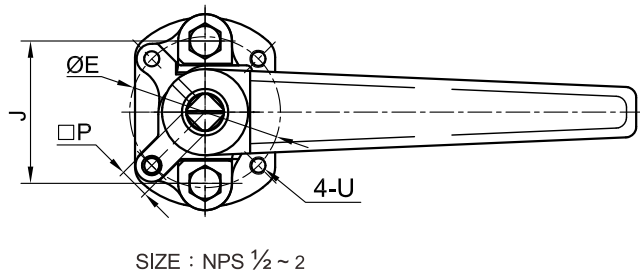
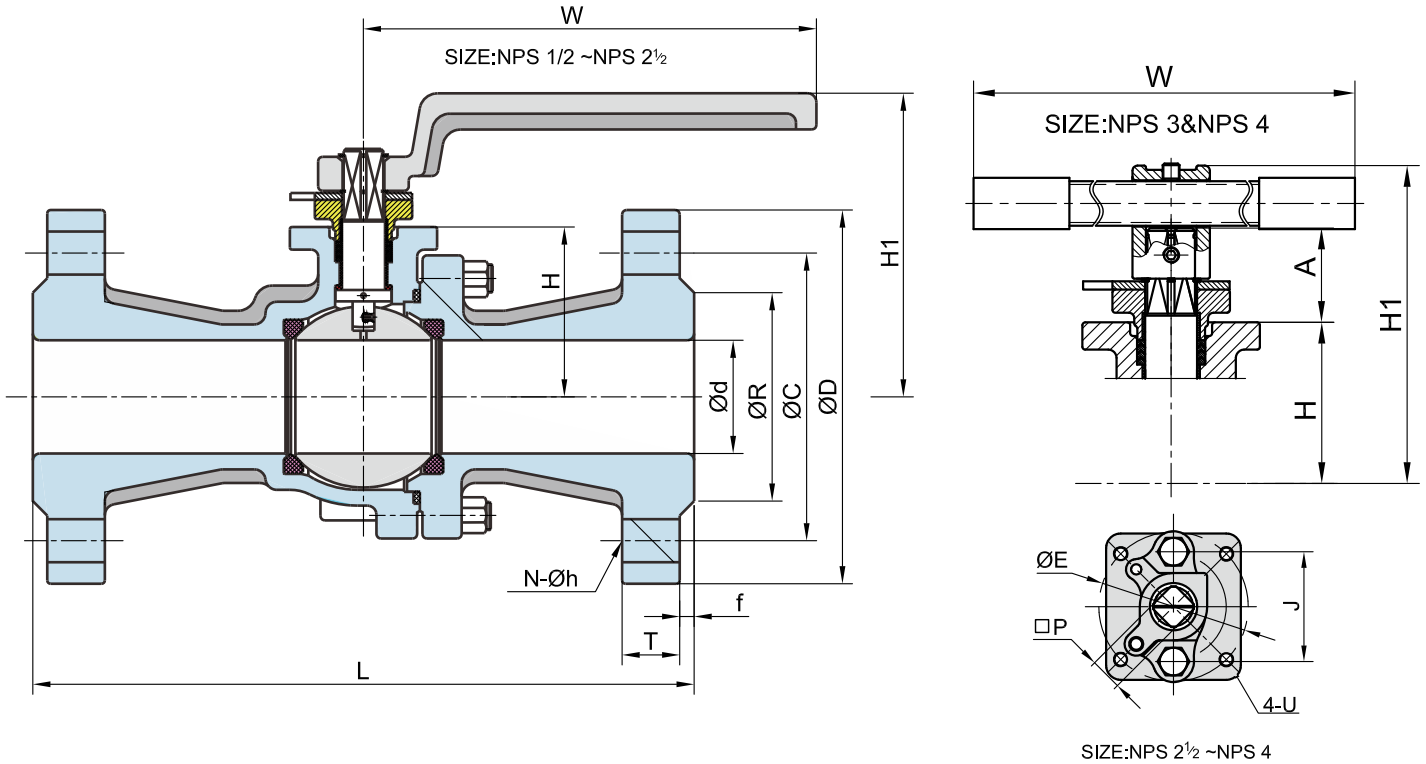

DIMENSION TABLE

ASME Class 600 DIMENSION TABLE

Unit : mm

NPS	d	L	R	D	C	f	T	H	H1	N	h	W	P	A	J	U	E	ISO 5211
1/2	15.0	165	35.0	95	66.5	6.4	14.2	39.0	89	4	16.0	130	9.0	23.2	40	M5	42	F04
3/4	20.0	190	42.9	117	82.6	6.4	15.7	46.3	96	4	19.0	130	9.0	23.2	40	M5	42	F04
1	25.0	216	50.8	124	88.9	6.4	17.5	53.0	107	4	19.0	160	11.0	27.0	50	M6	50	F05
1 1/4	32.0	229	63.5	133	98.6	6.4	20.6	59.5	115	4	19.0	160	11.0	27.0	50	M6	50	F05
1 1/2	38.0	241	73.2	155	114.3	6.4	22.4	66.0	127	4	22.2	265	14.0	34.5	66	M8	70	F07
2	50.0	292	91.9	165	127.0	6.4	25.4	77.0	136	8	19.0	265	14.0	34.5	66	M8	70	F07
2 1/2	63.5	330	104.6	190	149.4	6.4	28.4	98.5	166	8	22.2	265	17.0	50.3	75	M10	102	F10
3	76.0	356	127.0	210	168.1	6.4	31.8	108.0	206	8	22.2	400	17.0	50.3	75	M10	102	F10
4	100.0	432	157.2	273	215.9	6.4	38.1	136.0	240	8	25.4	400	22.0	55.4	75	M10	102	F10

ASME Class 600 DIMENSION TABLE

Unit : inch

NPS	d	L	R	D	C	f	T	H	H1	N	h	W	P	A	J	U	E	ISO 5211
1/2	0.59	6.50	1.38	3.75	2.62	0.25	0.56	1.54	3.50	4	5/8	5.12	0.354	0.91	1.57	M5	1.65	F04
3/4	0.79	7.50	1.69	4.62	3.25	0.25	0.62	1.82	3.78	4	3/4	5.12	0.354	0.91	1.57	M5	1.65	F04
1	0.98	8.50	2.01	4.88	3.50	0.25	0.69	2.09	4.21	4	3/4	6.30	0.433	1.06	1.97	M6	1.97	F05
1 1/4	1.26	9.00	2.50	5.25	3.88	0.25	0.81	2.36	4.53	4	3/4	6.30	0.433	1.06	1.97	M6	1.97	F05
1 1/2	1.50	9.50	2.88	6.12	4.50	0.25	0.88	2.60	5.00	4	7/8	10.43	0.551	1.36	2.60	M8	2.76	F07
2	1.97	11.50	3.62	6.50	5.00	0.25	1.00	3.03	5.35	8	3/4	10.43	0.551	1.36	2.60	M8	2.76	F07
2 1/2	2.50	13.00	4.12	7.50	5.88	0.25	1.12	3.90	6.54	8	7/8	10.43	0.669	1.98	2.95	M10	4.02	F10
3	2.99	14.00	5.00	8.25	6.62	0.25	1.25	4.25	8.03	8	7/8	15.75	0.669	1.98	2.95	M10	4.02	F10
4	3.94	17.00	6.19	10.75	8.50	0.25	1.50	5.35	9.45	8	1	15.75	0.866	2.18	2.95	M10	4.02	F10